

# THE FURNACE EXCHANGE

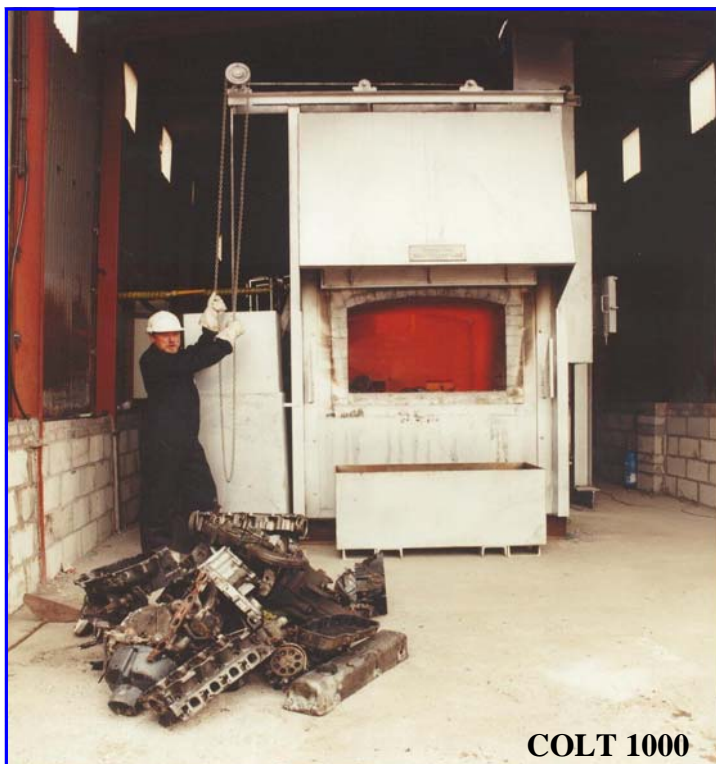

Unit IA, Newhaven Enterprise Centre, Denton Island, Newhaven, East Sussex, BN9 9BA

A range of recycling furnaces to produce high value ingots from scrap. Supplied complete, fully refractory lined with high temperature side flue afterburner and chimney. Full back up service for commissioning and training is available.



COLT 1000



Model	Chamber Internal Size			OUTPUT INGOTS PER DAY	
	L	W	H	(Average Irony)	(Semi Clean)
Colt 500	1041	762	610	500kgs	750kgs
Colt 1000	1220	915	685	750kgs	1000kgs
Colt 1500	1524	1066	762	1000kgs	1500kgs



Ingot Moulds available



COLT 500



COLT 750



Where applicable, monitoring instrumentation is available.

DO NOT SCALE - IF IN DOUBT ASK

THIRD ANGLE PROJECTION

ISS

MODIFICATION

DATE

# COLT JUNIOR 500 WITH STANDARD CHIMNEY AFTERBURNER

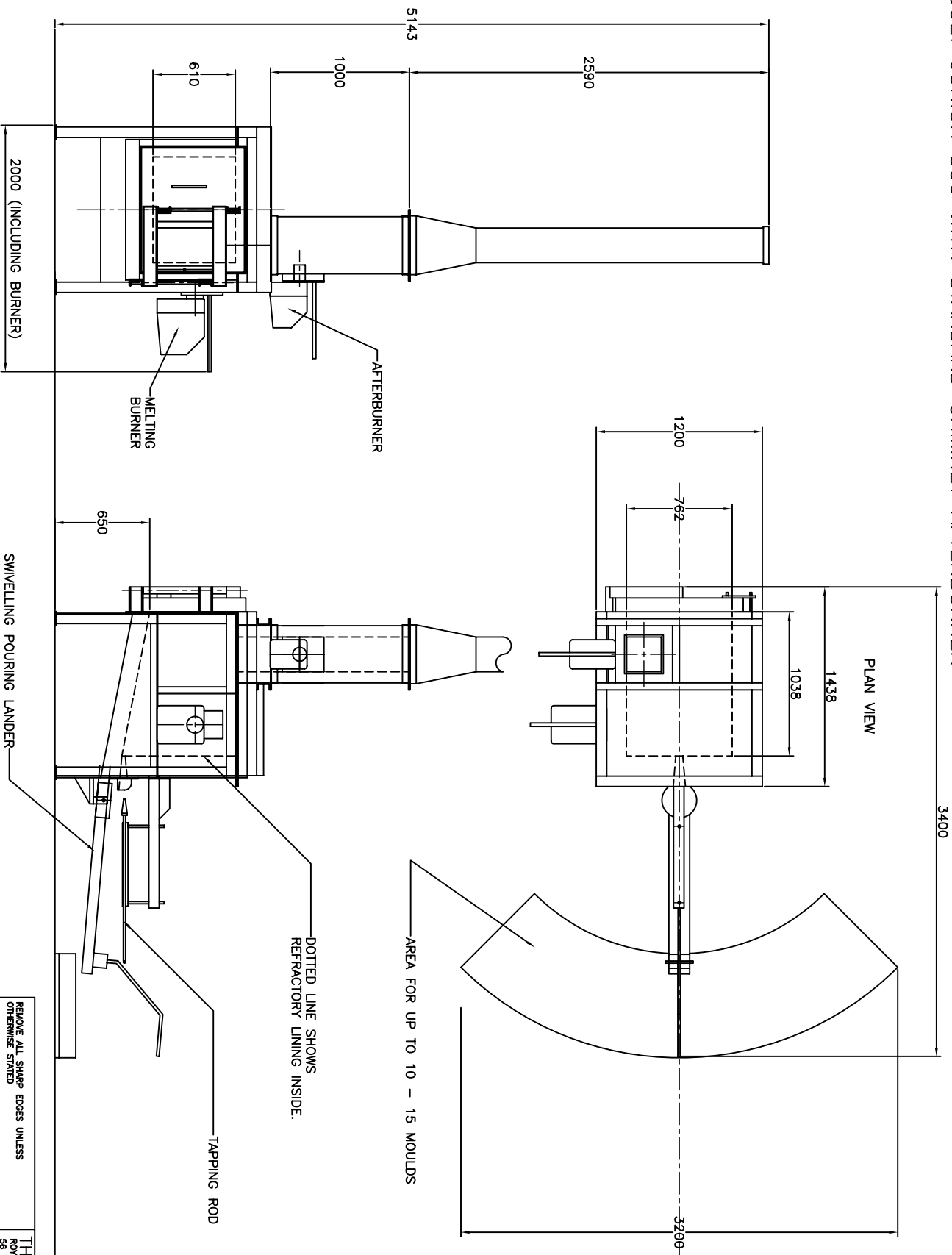

AREA FOR UP TO 10 - 15 MOULDS

DOTTED LINE SHOWS REFRACTORY LINING INSIDE.

TAPPING ROD

SWIVELLING POURING LANDER

MELTING BURNER

AFTERBURNER

2000 (INCLUDING BURNER)

PLAN VIEW

THIS DRG USED ON THE FOLLOWING ASSEMBLIES				DRN	DATE	CHNG SCALE	SURFACE FINISH	TOL CLASS	FILE NAME	PROTECTIVE FINISH	MATERIAL	NO OFF	DRG No
				04.05.05					REMOVE ALL SHARP EDGES UNLESS OTHERWISE STATED	ACAD			2002847
THE FURNACE EXCHANGE													
ROY HALL COMBUSTION LTD.													
58 WELINGTON ROAD, DENTON													
NEWHAVEN, EAST SUSSEX BN9 0RH													
TEL/FAK: 01273 517119													
COLT 500 'JUNIOR'													

DO NOT SCALE - IF IN DOUBT ASK

THIRD ANGLE PROJECTION

ISS

MODIFICATION

DATE

COLT	750	1000
SC	610	762
A	915	1067
B	1220	1524
C	2950	3105
D	4400	4750
E	3990	4150
F	8000	8000
G	3650	4000
H	3650	4000
J	3650	4000

PLAN VIEW

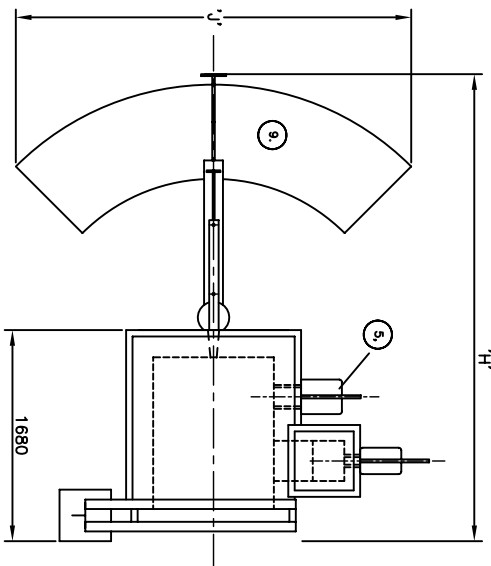

- KEY:
- AFTERBURNER BURNER
  - AFTERBURNER CHAMBER 2 SECS RETENTION.
  - THERMOCOUPLE
  - CONTROL PANEL
  - MELTING BURNER
  - SLOPING HEARTH MELTING CHAMBER
  - HOLDING WELL
  - BIN FOR SEPARATED IRON FROM HEARTH.
  - INGOT CASTING AREA.
  - EXTRACTION COWL OVER CHARGING DOOR.
  - DUCT FROM COWL INTO AFTERBURNER.
  - TAP OUT SYSTEM FOR CASTING MOLTEN METAL
  - CROSS STACK CONTINUOUS PARTICULATE MONITOR.
  - SAMPLING POINT FOR NON CONTINUOUS MONITORING.
  - COME ON STACK TO GIVE 15M/SEC EFFLUX VELOCITY.

NOTE:

STANDARD STACK HEIGHT SHOWN MINIMUM 8M FROM GROUND.  
FINAL STACK HEIGHT CALCULATED TO SUIT ACTUAL BUILDING AND SITE CONDITIONS.

SECTION THROUGH MELTING HEARTH  
SHOWING HOLDING WELL

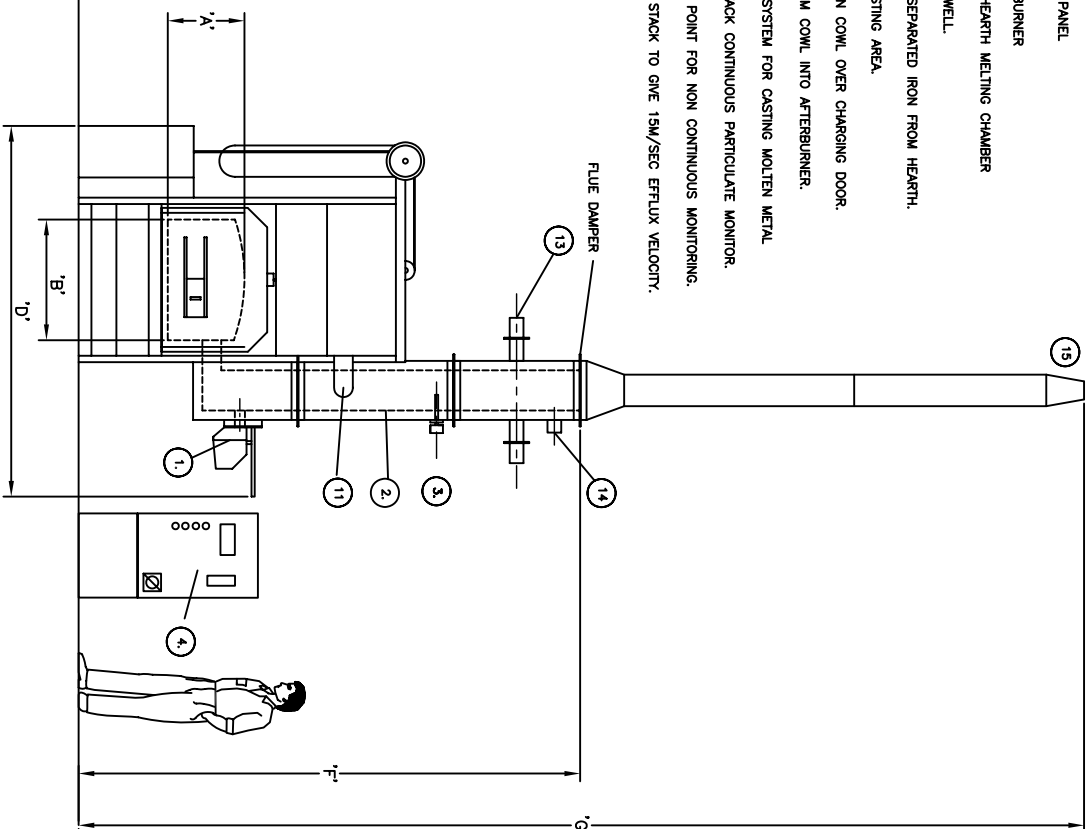
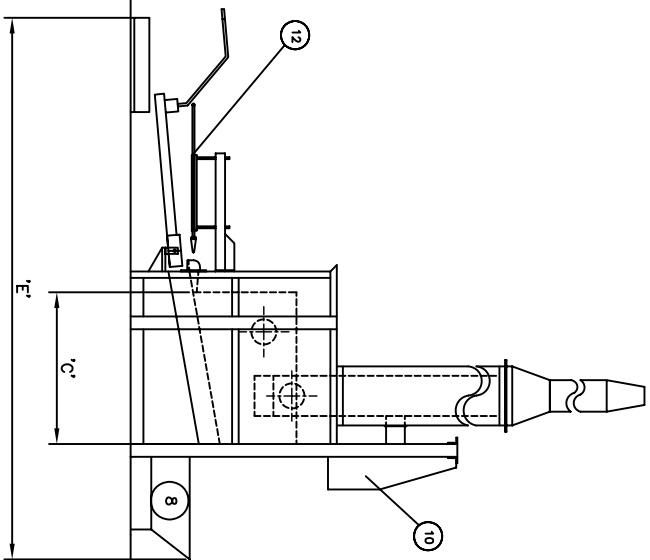
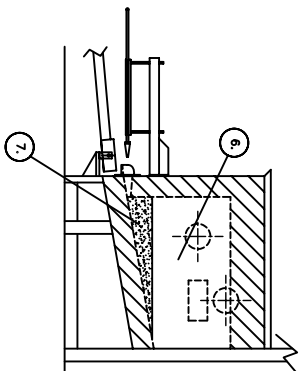

ALL DIMENSIONS PROVISIONAL ONLY

THIS DRG USED ON  
THE FOLLOWING  
ASSEMBLIES

DRN DATE  
18.12.2008

CHNO SCALE

SURFACE FINISH

TOL CLASS

PROTECTIVE FINISH

MATERIAL

No OFF

DRG No

3002944

REMOVE ALL SHARP EDGES UNLESS OTHERWISE STATED

FILE NAME

ACAD

No OFF

DRG No

3002944

THE FURNACE EXCHANGE  
ROY HALL COMBUSTION LTD.  
56 WELLINGTON ROAD, DENTON  
NEWMARVEN, EAST SUSSEX BN9 0RH  
TEL/FAX: 01273 517119